

SUP
ER
FICI
PRO
FON
DE

DE
EP
SUR
FA
CES

ARBI



SUP
ER
FICI
PRO
FON
DE
/
DE
EP
SUR
FA
CES

ARBI

SKY LACCATO & SKY RAVE

Che cos'è il colore? Una vibrazione della luce, una percezione fisica, un'emozione estetica, un linguaggio senza parole? Per Arbi è il protagonista di un progetto che interpreta la sala da bagno contemporanea, dando ad ogni spazio e situazione una particolare personalità e un senso preciso. Grazie a una gamma ampia e ricercata di finiture laccate, questo spazio si veste di volta in volta di tonalità classiche o contemporanee, classiche o di tendenza, in armonia con lo stile della casa ed i gusti dei suoi abitanti. Una scelta non superficiale o dettata dalle mode del momento, ma al contrario basata su una profonda ricerca e cultura del progetto: per trasformare il bagno in un'esperienza calda, viva, brillante.

What is colour? A vibration of light, a physical perception, an aesthetic emotion, a language without words? For Arbi it plays a central role in a project that interprets the contemporary bathroom, giving each space and situation a particular character and a precise sense. Thanks to a broad and tasteful range of lacquer finishes, the space is dressed in classic or contemporary tones, in tune with the style of the house and the tastes of those who live there. A choice that is not superficial or dictated by fleeting fashions, and is based on in-depth research and design culture: transforming the bathroom into a warm, lively, bright experience.

Was ist Farbe? Eine Schwingung des Lichts, eine körperliche Empfindung, eine ästhetische Emotion, eine wortlose Sprache? Für Arbi ist sie Protagonist im Design für ein Badambiente im Zeitgeist, das jedem Raum und jeder Gegebenheit eine besondere Individualität und einen präzisen Sinn zuweist. Dank eines umfangreichen Programms und der eleganten Lackausführung, kann sich der Raum in klassischen oder zeitgemäßen, klassischen oder modisch trendigen Farbtönen zeigen, die sich stets harmonisch in den Stil des Hauses und in den Geschmack seiner Bewohner einfügen. Eine Wahl, die weder oberflächlich ist noch von wechselnden Moden diktiert wird, sondern auf gründlicher Forschung und Designkultur beruht: um das Badezimmer in ein warmes, lebendiges und brillantes Ambiente zu verwandeln.





COMP. INDEX

COMP.	PAG	COMP.	PAG	COMP.	PAG
140	06	149	66	157	120
141	12	150	72	152	126
142	20	151	78	05	127
143	26	34	82	153	128
144	32	33	88	74	129
145	40	36	94	77	130
146	46	154	102	79	131
147	54	155	110		
148	60	156	116		

SKY COMP. 140

BIANCO OPACO

FUMO DI LONDRA

SKY LACCATO

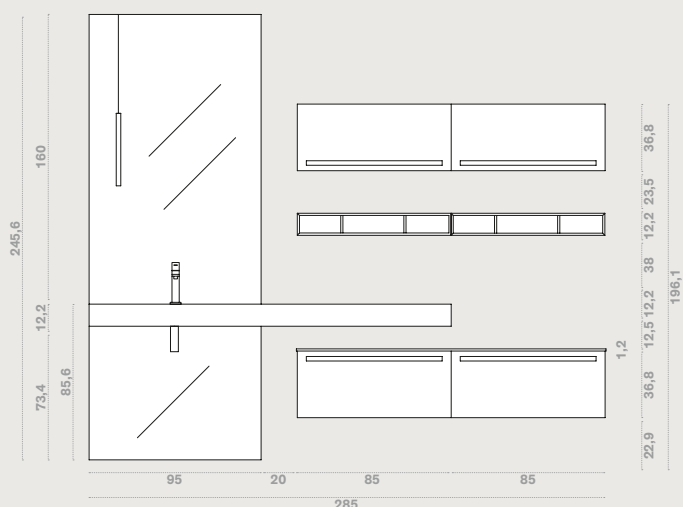

L 285 x P 50,5 cm

SKY LACCATO / COMP 140

Il bianco opaco, il più puro e minimalista dei colori, veste questa composizione basata su importanti volumi orizzontali, affiancati dal grande specchio verticale ed interrotti dall'inserimento dei vani contenitori Kubo laccati fumo di Londra opaco. Il piano in laminam Ossidiana Vena scura è dotato di lavabo Plaza perfettamente integrato nella sua superficie. Il faretto Piro a sospensione a luce led riprende la linea verticale dello specchio. I vani a giorno della vasca Coccole sono intonati alla tinta dei contenitori Kubo sulla parete.

Matt white, the purest, most minimalist of colours, adorns this composition based on imposing horizontal volumes, flanked by a large vertical mirror and interposed with Kubo storage containers in matt Fumo di Londra lacquer. The top in dark Ossidiana Vena laminam is fitted with a Plaza washbasin perfectly integrated into the surface. The Piro hanging LED spotlight echoes the vertical line of the mirror. The open compartments of the Coccole bathtub match the shade of the Kubo containers on the wall.

Mattes Weiß, die so reine und minimalistische Farbe, bekleidet diese Komposition, die auf anspruchsvollen, horizontalen Volumen basiert, flankiert vom großen, vertikalen Spiegel und unterbrochen durch Schrankelemente Kubo in Mattlackierung Fumo di Londra. Die Platte aus Laminam Ossidiana dunkle Maserung ist mit einem Becken Plaza ausgestattet, das perfekt in die Oberfläche integriert ist. Der hängende LED-Strahler Piro nimmt die vertikale Linie des Spiegels wieder auf. Die offenen Fächer der Wanne Coccole sind der Farbe der Schrankelemente Kubo angepasst, die an der Wand montiert sind.







COMP. 140

SKY LACCATO

ARBI





SKY COMP. 141



BOSCO LUCIDO

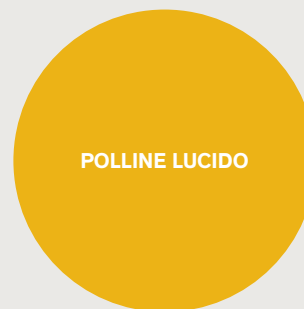

POLLINE LUCIDO

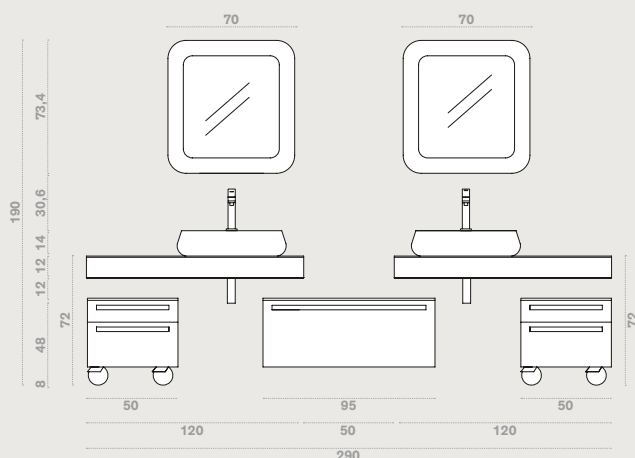

L 290 x P 50,5 cm

SKY LACCATO / COMP 141

Fresche e naturali le tonalità Polline e Bosco di questa composizione, con due strutture portalavabo sospese, dotate di piano in quarzo resina in finitura Fango Rocface incassato e lavabo ad appoggio Geo in mineralguss. La specchiera Jolly è in vetro verniciato Polline, con luce led integrata che ne staglia visivamente il profilo. La stessa tonalità caratterizza uno dei due pratici contenitori su ruote, facilmente spostabili all'interno della stanza da bagno.

The fresh and natural Polline and Bosco hues of this composition adorn the two suspended vanity units, fitted with a sunken quartz resin top in a Rocface Fango finish and a Geo countertop washbasin in Mineralguss composite. The Jolly mirror unit is in Polline painted glass, with integrated LED light visually cutting across its profile. The same shade is featured in one of the two handy wheeled containers, which can be easily moved around the bathroom.

Frisch und natürlich die Farben Polline und Bosco dieser Zusammenstellung: zwei hängende Waschtischunterbauten mit integrierter Platte aus Quarz-Kunstharz in der Ausführung Fango Rocface und Aufsatzbecken Geo aus Mineralguss. Der Spiegel Jolly ist aus lackiertem Glas in der Farbe Polline, mit integrierter LED-Beleuchtung, die das Profil optisch attraktiv zur Geltung bringt. Die gleiche Farbe schmückt eines der beiden praktischen Schrankmöbel auf Rollen, die sich leicht im Bad verschieben lassen.



COMP. 141

SKY LACCATO

ARBI













SKY COMP. 142

BIANCO OPACO

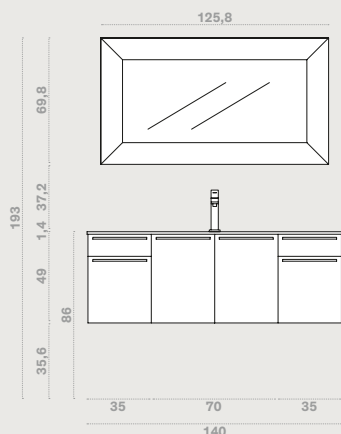

CON SPORGENZA CONSOLLE
L 141 x P 38 / 50,8 cm

SKY LACCATO / COMP 142

Preziosamente moderna, questa sala da bagno abbina una composizione Sky laccata bianco opaco con una consolle Joy in mineralguss dallo spessore estremamente sottile: appena 14 mm. Sinuose e raffinate le curve della base portalavabo Fusion, con cassettiere laterali e maniglie Line, tutto in tonalità bianco opaco. Particolarmente affascinante la specchiera Guru con cornice in legno impreziosita da decori in argento. Disponibile in diverse misure e finiture, può essere ulteriormente arricchita da una luce a led integrata.

Elegantly modern, this bathroom combines a matt white lacquered Sky composition with a Joy console in ultraslim Mineralguss composite: just 14 mm thick. The Fusion vanity unit features sleek, refined curves with drawer units to the sides and Line handles, all in matt white. The Guru mirror unit with its wooden frame decorated in silver is particularly charming. Available in a range of sizes and finishes, it can be further enhanced with an integrated LED light.

Kostbar modern ist dieses Badezimmer, in dem sich eine Komposition Sky matt weiß lackiert mit einer Konsole Joy aus Mineralguss in ebenso schlanker Stärke verbindet: gerade einmal 14 mm. Raffiniert die geschwungene Form des Waschtischunterbaus Fusion, mit seitlichen Schubladen und Griffen Line, alle in weißer Farbe matt. Besonders auch der bezaubernde Spiegel Guru mit dem Holzrahmen mit kostbarer Silberverzierung. Erhältlich in verschiedenen Maßen und Farben, kann er auch mit integrierter LED-Beleuchtung ausgestattet werden.







COMP. 142

SKY LACCATO

ARBI





SKY COMP. 143

BIANCO OPACO

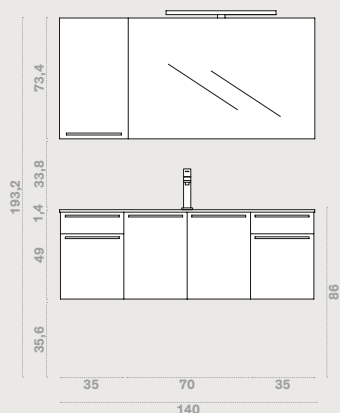

CON SPORGENZA CONSOLLE
L 141 x P 38 / 50,8 cm

SKY LACCATO / COMP 143

Un'interpretazione del bagno attenta alla funzionalità, senza perdere di vista l'eleganza. La composizione Sky laccata bianco opaco, con consolle Joy in mineralguss di spessore 14 mm, è abbinata a uno specchio De Lux con faretto Nemo a luce led, a sua volta affiancato da un pensile ad un'anta. Una soluzione che amplia le possibilità di contenimento offerte dalle cassettiere laterali con maniglie Line, sempre in tonalità bianco opaco.

An interpretation of the bathroom with an eye to functionality, as well as maintaining constant elegance. The matt white lacquered Sky composition, with Joy console in 14 mm Mineralguss composite is combined with a De Lux mirror with Nemo LED spotlight, alongside a single wing-door wall unit. This solution expands the possibilities for storage offered by the lateral drawer units with Line handles, again in a matt white tone.

Die funktionsorientierte Interpretation eines Badezimmers, das aber auf eleganten Stil keinesfalls verzichtet. Eine Komposition Sky weiß matt lackiert, mit Konsole Joy aus Mineralguss, Plattenstärke 14mm, in Verbindung mit Spiegel De Lux mit LED-Strahler Nemo, flankiert von einem eintürigen Oberschrank. Eine Lösung, die den Stauraum der beiden seitlichen Schubladen mit Griffen Line, ebenfalls in mattweißer Ausführung, zusätzlich erweitert.











SKY COMP. 144

FUMO DI LONDRA OPACO

TANGO OPACO

SKY LACCATO

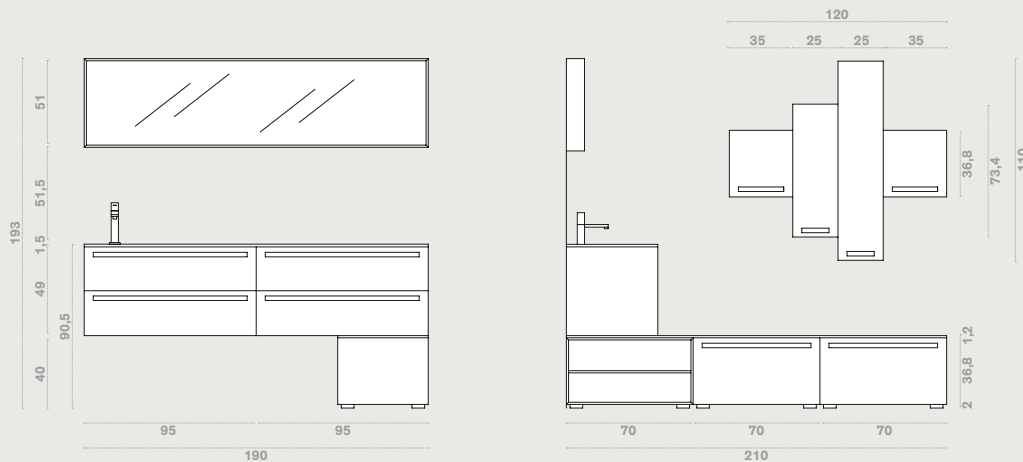

CON SPORGENZA TOP
L 190,5 x P 50,5 cm

SKY LACCATO / COMP 144

Dedicata agli spazi più ampi, questa composizione laccata Fumo di Londra opaco è resa molto particolare alla vista dall'abbinamento con la tonalità Tango opaco della maniglia Cosmo, ripreso anche dal piano di cristallo satinato, con grande lavabo Occhio morbidamente integrato sulla sua superficie. Le basi sono dotate di cassettoni e vani a giorno, la parete è attrezzata con pensili in diverse colorazioni tono su tono. Un ulteriore piano di appoggio è offerto dalla cornice perimetrale della specchio Folding, con doppia luce a led.

Dedicated to wider spaces, this composition in matt Fumo di Londra lacquer features a distinctive combination with the matt Tango shade of the Cosmo handle, echoed in the frosted crystal glass top, with the large Occhio washbasin softly integrated into the surface. The vanity units are fitted with drawers and open compartments, complemented by wall-mounted units in a number of tone-on-tone colours. Further shelf space is provided by the frame around the Folding mirror unit, with double LED light.

Für größere Räume ist diese Komposition in Mattlack Fumo di Londra gedacht, die durch die Verbindung mit der Farbe Tango matt der Griffe Cosmo besondere optische Akzente erhält, eine Farbe, die von der Glasplatte, satiniert, mit dem weich integrierten, großen Becken Occhio, aufgegriffen wird. Die Unterschränke sind mit Schubladenelementen und offenen Fächern ausgestattet, die Wände mit Oberschränken in verschiedenen, koordinierten Farben. Eine weitere Ablage bietet der umlaufende Rahmen von Spiegel Folding, mit doppelter LED-Beleuchtung.



COMP. 144

SKY LACCATO

ARBI













SKY COMP. 145

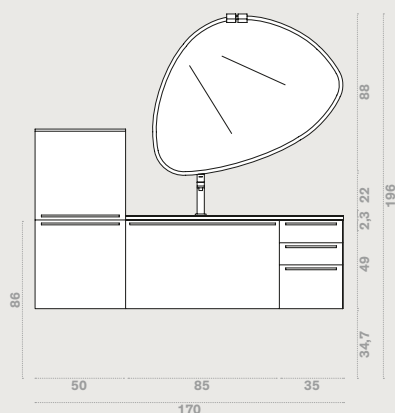
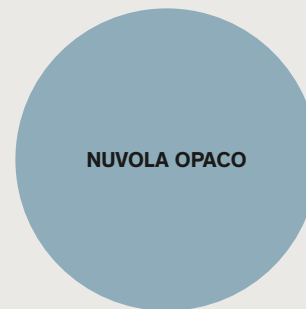

CON SPORGENZA CONSOLLE
L 170,5 x P 37 / 50,8 cm

SKY LACCATO / COMP 145

La sognante tonalità Nuvola Opaco contraddistingue questa composizione dallo spirito delicato e artistico, ma allo stesso tempo provvista di una totale funzionalità. Ante, cassettiere e base portalavabo curva creano un insieme completo, anche in uno spazio compatto. La specchiera Stone s' inserisce nella composizione con la sua particolare forma, aggiungendo un senso di dinamismo. La consolle Zero in mineralguss, con lavabo integrato, ha uno spessore di soli 2,3 cm.

The dreamy hue Nuvola Opaco distinguishes this composition with its delicate, artistic spirit, which still offers absolute functionality. Storage containers, drawer units and curved vanity unit create a complete whole, even in a compact space. The Stone mirror unit complements the composition with its distinctive shape, adding a sense of dynamism. The Zero console in Mineralguss composite, with integrated washbasin, has a thickness of just 2.3 cm.

Die verträumte Farbe Nuvola Opaco bestimmt den zarten, künstlerischen Charakter dieser Zusammenstellung, die aber dennoch überaus zweckmäßig ist. Schrankmöbel, Schubladen und bogenförmiger Waschtischunterbau schaffen eine komplette Einheit auch in kleineren Räumen. Der Spiegel Stone im besonderen Design, fügt sich harmonisch in die Zusammenstellung ein und sorgt für dynamische Effekte. Die Konsole Zero aus Mineralguss, mit integriertem Becken, hat eine schlanke Platte von nur 2,3 cm Stärke.











SKY COMP. 146

GHIACCIO LUCIDO

SKY LACCATO

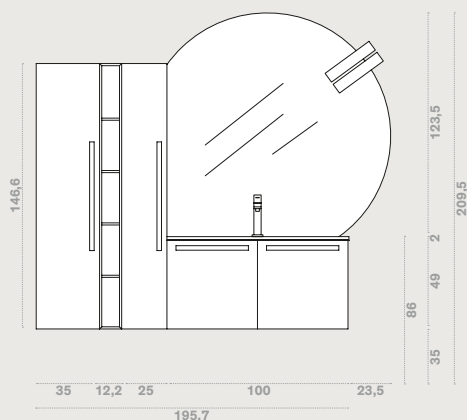

CON SPORGENZA SPECCHIO
L 195,7 x P 20,8 / 51 cm

SKY LACCATO / COMP 146

Una composizione dominata dal fascino del Ghiaccio Lucido, in un gioco visivo tono su tono con le maniglie Cosmo integrate nelle ante, nella stessa tonalità ma con finitura opaca. Il vano a giorno Kubo laccato Creta opaco si inserisce tra le due colonne contenitore. Il piano in marmo quarzo resina nella finitura Rocface Torba, comprende il lavabo a incasso Aral in ceramica. La specchiera Sole con faretto Mata a luce led completa il tutto con un grande e armonioso segno di luce e di riflessi. Per finire, un tocco di classe in più: la vasca freestanding Kuvet in mineralguss lucido.

A composition dominated by the attractive Ghiaccio Lucido palette, a visual interplay of tone on tone with Cosmo handles integrated into the doors, in the same shade, but with a matt finish. The matt Creta lacquered Kubo open compartment fits in between the two storage columns. The quartz marble resin top in a Rocface Torba finish includes an Aral ceramic sunken washbasin. The Sole mirror unit with Mata LED spotlight completes the composition with a large and harmonious effect of light and reflections. To finish it off, an extra touch of class: Kuvet freestanding bathtub in glossy Mineralguss composite.

Eine von der zauberhaften Glanzfarbe Ghiaccio Lucido geprägte Komposition in spielerischer Ton-in-Ton Optik mit den eingelassenen Griffen Cosmo, die aber matt ausgeführt sind. Das offene Möbel Kubo, lackiert Creta matt, ist zwischen den beiden Säulen mit Stauraum eingesetzt. Die Platte aus technischem Marmor Quarz-Kunstharz in der Ausführung Rocface Torba, enthält auch das eingebaute Keramikbecken Aral. Spiegel Sole mit LED-Strahler Mata vervollständigt die Einrichtung, die von großer Harmonie aus Licht und Spiegelungen geprägt wird. Zum Abschluss, ein weiteres Plus an Klasse: die freistehende Wanne Kuvet aus Mineralguss glänzend.



COMP. 146

SKY LACCATO

ARBI













SKY COMP. 147

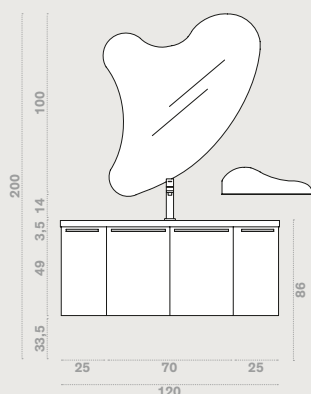

CON SPORGENZA MENSOLA
L 135 x P 10,8 / 50,8 cm

SKY LACCATO / COMP 147

Raffinata e contenuta, questa composizione con base porta lavabo e terminali Fusion curvi si presenta nell'elegante laccatura Petrolio lucido. La consolle Strike in mineralguss, segue perfettamente le curve della composizione, mentre la specchiera Cuore con luce led integrata aggiunge un elemento emozionale ed originale. La mensola Move, sempre laccata Petrolio lucido, completa il tutto con un utile piano d'appoggio.

Refined and compact, this composition with vanity unit and Fusion curved end pieces features an elegant shade of glossy Petrolio lacquer. The Strike console in Mineralguss composite, follows the curves of the composition perfectly, while the Cuore mirror unit with integrated LED light adds an original and touching element. Move shelves, again in glossy Petrolio lacquer, complete the look with some handy storage space.

Raffiniert und kompakt, präsentiert sich diese Einrichtung mit Waschtischunterbau und Seitenelementen Fusion im bogenförmigen Design in der eleganten Glanzlackierung Petrolio. Die Konsole Strike aus Mineralguss folgt perfekt den Kurvenlinien der Komposition, während der Spiegel Cuore mit integrierter LED-Beleuchtung, ein originelles Element von lebendiger Faszination hinzufügt. Die Wandkonsole Move, ebenfalls in Glanzlack Petrolio, macht die Einrichtung mit einer praktischen Ablage komplett.







COMP. 147

SKY LACCATO

ARBI





SKY COMP. 148

ROSA BABOL OPACO

CICLAMINO LUCIDO

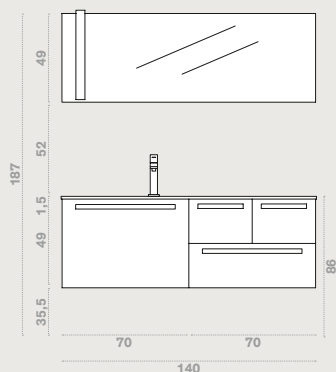

CON SPORGENZA TOP
L 141 x P 37,5 cm

SKY LACCATO / COMP 148

Romantico l'abbinamento fra le tonalità Ciclamino e Rosa Babol, fra superfici laccate opache e lucide che integrandosi creano un'unica emozione. La colorazione Ciclamino è ripresa dal piano in cristallo con lavabo Little integrato, profondo appena 37,5 cm. Originale e di grande effetto il faretto Stelo a luce led, applicato alla specchiera Light. La maniglia Cosmo integrata nel mobile riprende le stesse colorazioni dei frontali dei cassetti, sempre con finitura opaca.

The romantic combination of Ciclamino and Rosa Babol, amid lacquered and glossy surfaces that integrate to create a single sensation. The Ciclamino colour is echoed by the crystal glass top with Little integrated washbasin, just 37.5 cm deep. Original and highly striking, the Stem LED spotlight applied to the Light mirror unit. The Cosmo handle integrated into the unit echoes the same hues seen in the front panels of the drawers, again in a matt finish.

Romantisch die Verbindung zwischen den Farben Ciclamino und Rosa Babol, zwischen lackierten und glänzenden Flächen, die sich zu einer einzigen Emotion zusammenfügen. Die Farbe Ciclamino wird auch von der Glasplatte mit integriertem Becken Little, nur 37,5 cm tief, aufgegriffen. Originell und effektiv der LED-Strahler Stelo, der am Spiegel Light montiert ist. Der im Möbel eingelassene Griff Cosmo wiederholt die Farbtöne der Ladenfronten, ebenfalls in matter Ausführung.



COMP. 148

SKY LACCATO

ARBI









SKY COMP. 149

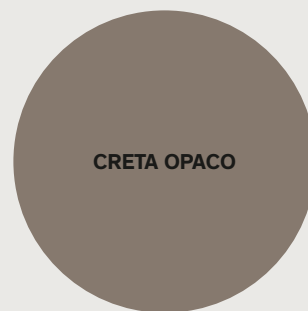

CRETA OPACO

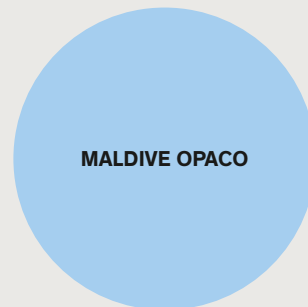

MALDIVE OPACO

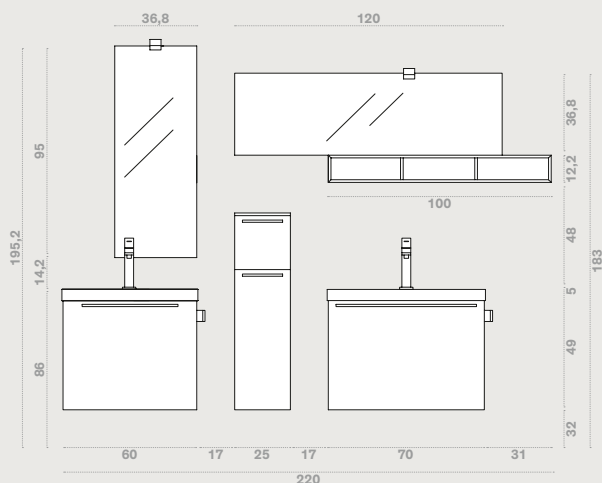

L 220 x P 51 / 15 cm

SKY LACCATO / COMP 149

Una coppia di elementi in perfetta armonia, ognuno con una propria personalità cromatica: Maldive e Creta opaco. Un'individualità sottolineata da una lieve differenza di larghezza (60 e 70 cm). Attrezzati sul lato con portasalviette Snoopy e dotati di console Lego in mineralguss, sono completati da uno specchio in verticale ed uno in orizzontale, entrambi con faretto Genius a luce led. L'insieme è completato da una piccola colonna pensile e da un vano contenitore Kubo.

A pair of elements in perfect harmony, each with its own colourful personality: matt Creta and Maldive. Their individuality is emphasised by the slight difference in width (60 and 70 cm). Equipped to one side with Snoopy towel holder and fitted with a Lego console in Mineralguss composite, they are completed with one vertical and one horizontal mirror, both featuring a Genius LED spotlight. The composition is completed with a small wall column and Kubo storage compartment.

Zwei Elemente in perfekter Harmonie, jedes mit einer eigenen, farblichen Identität: Maldive und Creta matt. Eine Individualität, die von einer leicht unterschiedlichen Breite (60 gegenüber 70 cm) unterstrichen wird. Auf einer Seite mit Handtuchhalter Snoopy ausgestattet und mit Konsole Lego aus Mineralguss versehen, werden sie durch einen vertikalen und einen horizontalen Spiegel ergänzt, beide mit LED-Strahler Genius. Vervollständigt wird die Einrichtung durch eine kleine, wandhängende Säule und ein Schrankelement Kubo.



COMP. 149

SKY LACCATO



ARBI







SKY COMP. 150

BIANCO OPACO

FUMO DI LONDRA
OPACO

SKY LACCATO

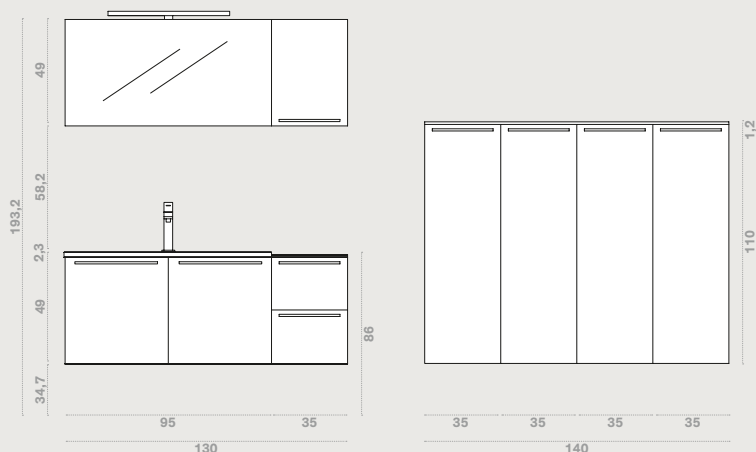

CON SPORGENZA CONSOLLE
L 130,5 x P 51 cm

SKY LACCATO / COMP 150

Sulle superfici laccate Bianco opaco si stacca la maniglia Line verniciata Fumo di Londra opaco, con un effetto raffinemente grafico. La consolle Panarea in ceramica bianca si inserisce nella base portalavabo a due ante, completata da una cassettera sul lato destro. La specchiera contenitore Vela con faretto Emy a luce led, presa-interruttore a scomparsa e apertura a ribalta, offre ulteriori spazi dedicati al contenimento. L'ambiente è completato da semi colonne che riprendono la tonalità Fumo di Londra, ma con finitura lucida.

On the matt Bianco lacquered surfaces, the Line handle painted in matt Fumo di Londra stands out strikingly, creating a refined graphic effect. The Panarea console in white ceramic fits into the two-door vanity unit, completed with a drawer unit to the right. The Vela storage mirror unit with Emy LED spotlight, concealed socket and switch and flap door opening, offers further storage space. The setting is completed with semi columns echoing the Fumo di Londra shade, but with a glossy finish.

Von den matt Bianco lackierten Flächen hebt sich grafisch effektiv der Griff Line in der Farbe Fumo di Londra matt ab. Die Konsole Panarea in weißer Keramik fügt sich in den zweitürigen Waschtischunterbau ein, der auf der rechten Seite durch Schubladen vervollständigt wird. Der Spiegelschrank Vela mit LED-Strahler Emy, Steckdose mit Schalter verdeckt eingebaut, mit Kippöffnung, hat weiteren Stauraum zu bieten. Die Einrichtung wird durch Halbsäulen vervollständigt, die in glänzender Ausführung - die Farbe Fumo di Londra aufgreifen.



COMP. 150

SKY LACCATO

ARBI





COMP. 150

SKY LACCATO

ARBI





SKY COMP. 151



TERRANOVA LUCIDO

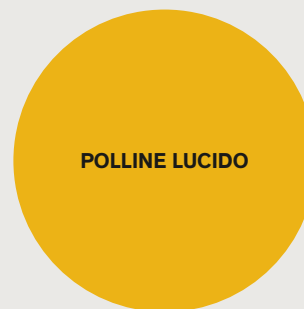

POLLINE LUCIDO

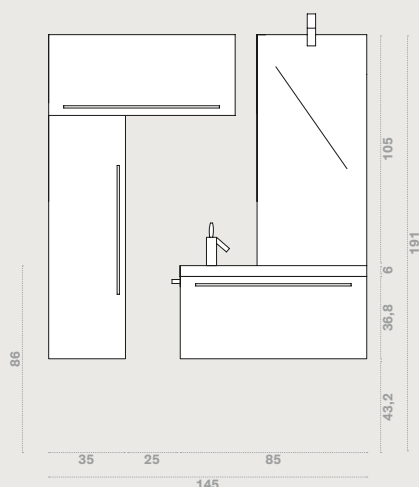

CON SPORGENZA CONSOLLE
L 145,5 x P 20,8 / 38 cm

SKY LACCATO / COMP 151

Polline e Terranova lucido: due tonalità piacevolmente contrastanti per questa soluzione dedicata agli ambienti più compatti, con base dotata di portasalviette laterale e lavabo consolle Brick in ceramica. Profondo appena 38 cm, è disponibile in varie larghezze per ottimizzare al meglio lo spazio disponibile, sempre con un comfort ottimale. La composizione è illuminata dal faretto metallico Genius.

Glossy Polline and Terranova: two pleasingly contrasting shades for this solution dedicated to more compact spaces, with a vanity unit fitted with towel rail on one side and a Brick console ceramic washbasin. Just 38 cm deep, it is available in a range of widths to make the very most of the available space, ensuring optimum comfort and convenience. The composition is lit up with a Genius metallic spotlight.

Polline und Terranova glänzend: zwei angenehm kontrastierende Farben in dieser Lösung für kompakte Räume; Unterschrank mit seitlichem Handtuchhalter und Waschtisch-Konsole Brick aus Keramik. Nur 38 cm tief, werden verschiedene Breiten angeboten, um den verfügbaren Raum optimal und immer mit idealem Komfort zu nutzen. Die Zusammenstellung wird vom metallischen Strahler Genius beleuchtet.







SKY COMP. 34

BIANCO LUCIDO

NERO LUCIDO

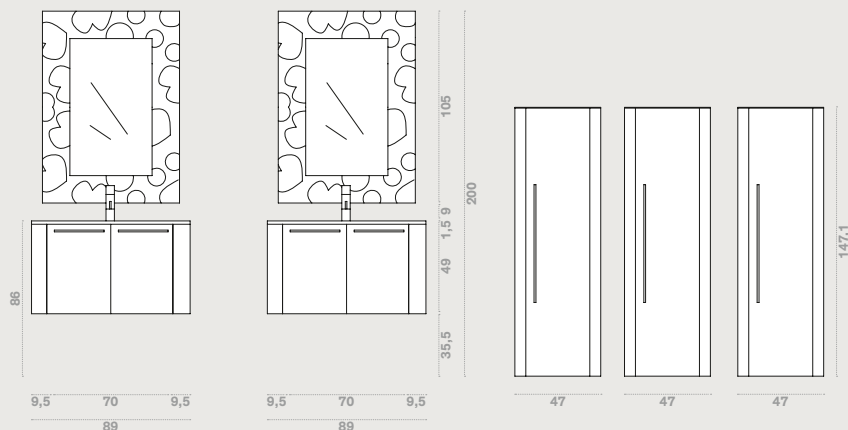

CON SPORGENZA TOP
L 90 x P 50,8 cm

SKY LACCATO / COMP 34

Un abbinamento che richiama la moda e l'arte "optical", quello fra le basi portalavabo in Bianco lucido e Nero lucido con piani in cristallo extralight satinato e lavabo armoniosamente integrato di forma ovale. Due specchiere Love caratterizzano amabilmente lo spazio con le loro cornici bianche o nere, impreziosite da intagli decorativi e illuminate da una luce a led integrata lungo il perimetro interno. Funzionalità pura e semplice per le colonne in tre tonalità complementari.

A combination evocative of fashion and "optical" art is what we find between the vanity units in glossy white and glossy black with extralight frosted crystal glass tops and harmoniously integrated oval washbasin. Two Love mirror units offer a pleasing personality to the space with their black or white frames, embellished with decorative fretwork and lit up by an integrated LED light integrated into the inside edge. Pure, unadulterated functionality for the columns in three complementary shades.

Eine Zusammenstellung, die mit den Waschtischunterbauten in glänzendem Weiß und glänzendem Schwarz, mit Glasplatten extralight satiniert und harmonisch integriertem Becken in ovaler Form, an Op-Art in Mode und Kunst erinnert. Zwei Spiegel Love mit ihren weißen oder schwarzen Rahmen prägen den Raum auf angenehme Art und erhalten zusätzliche, elegante Akzente durch dekorative Gravuren und die integrierte, auf der Innenseite umlaufende LED-Beleuchtung. Funktion in reinster und schlichter Form bieten die Säulen in drei komplementären Farben.



COMP. 34



SKY LACCATO



ARBI









SKY COMP. 33

SAFARI OPACO

SKY LACCATO

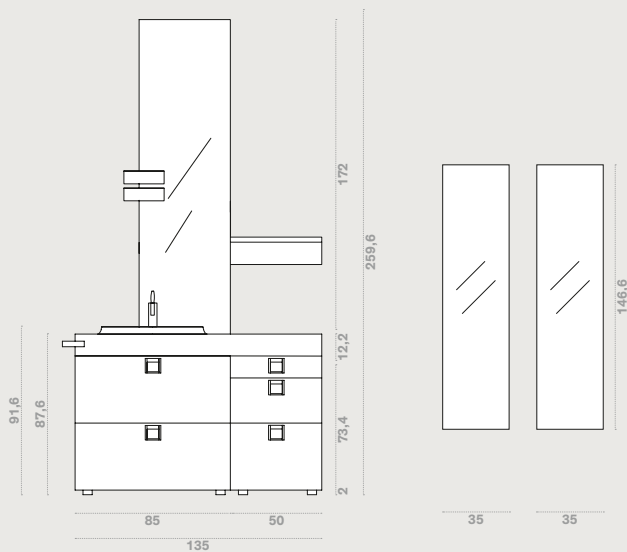

CON SPORGENZA PORTASALVIETTE
L 138,5 x P 50,5 cm

SKY LACCATO / COMP 33

Funzionale e raffinata questa composizione a terra, tutta in tonalità Safari opaco. Il cassettone, con maniglia Block a incasso, è attrezzato con contenitori portaoggetti e cestino portarifiuti. Il piano in Tekno opaco è dotato di lavabo Vulcano integrato. La specchiera a tutta altezza, con faretto Mata a luce led, è affiancata da una mensola con fianchi sagomati, uniti con tecnologia folding, e cassetto contenitore. L'ambiente è completato da colonne Midi con vani a giorno laterali e specchio frontale.

This floor-standing composition entirely in a matt Safari hue, is practical and elegant. The large drawer, with sunken Block handle, is equipped with storage containers and a waste bin. The Tekno matt top features an integrated Vulcano washbasin. The full-height mirror unit with Mata LED spotlight is flanked by a shelf with carved sides, combined with Folding technology, and a small drawer for storage. The setting is completed with Midi columns, with open side compartments and mirrored front.

Zweckmäßig und raffiniert diese am Boden aufgestellte Komposition, ganz in der Farbe Safari matt. Die Kommode, mit einglassendem Griff Block, ist mit Staufächern und Müllbehälter ausgestattet. In der Platte aus Tekno matt ist das Becken Vulcano integriert. Der Spiegel in voller Höhe, versehen mit LED-Strahler Mata, wird von einer Konsole mit geformten Seitenteilen, die in Folding-Technik verbunden ist, und einer kleinen Schublade flankiert. Der Raum wird vervollständigt durch Säulen Midi mit offenen Seitenfächern und Spiegelfront.







COMP. 33

SKY LACCATO



AR8



SKY COMP. 36

BIANCO LUCIDO

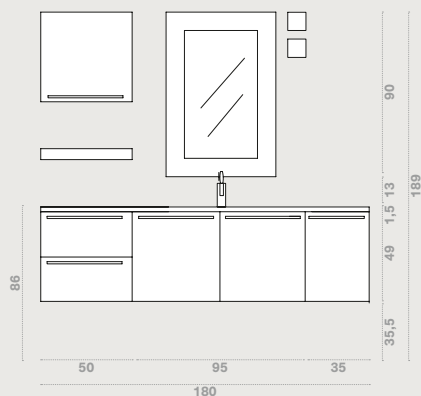

CON SPORGENZA TOP
L 181 x P 50,8 / 23,7 cm

SKY LACCATO / COMP 36

Bianco lucido e riflessi argentati, un connubio prezioso per interpretare una sala bagno dall'atmosfera elegantemente living. Il lavabo Afro è incastonato nel piano in cristallo extralight argento. La cornice della specchiera Diamante è composta da una moltitudine di frammenti di vetro argentato, che scintillano alla luce dei faretto Kubo a muro. La mensola di spessore importante (6 cm) è anch'essa dotata di luce a led integrata.

Glossy white with silvery reflections, an elegant combination to interpret a bathroom with an atmosphere so elegant you won't want to leave. The Afro washbasin is set into the extralight silver crystal glass top. The frame of the Diamante mirror unit comprises a multitude of fragments of silvered glass, which sparkle in the light of the wall-mounted Kubo spotlights. The extra thick shelf (6 cm) is also fitted with integrated LED light.

Weiß glänzend und silberne Reflexe, eine exklusive Union zur Interpretation eines Badezimmers mit eleganter Wohnatmosphäre. Das Waschbecken Afro ist in die silberfarbene Glasplatte extralight eingesetzt. Der Rahmen des Spiegels Diamante besteht aus zahllosen, versilberten Glassplittern, die im Licht der an der Wand montierten Strahler Kubo ein funkeln Licht aussenden. Die wuchtige Konsole (6 cm dick) ist ebenfalls mit integrierter LED-Beleuchtung ausgestattet.



COMP. 36

SKY LACCATO







COMP. 36

SKY LACCATO

ARBI



SKY RAVE COMP.

154 / 155
/ 156 / 157

SUP
ER
FICI
PRO
FON
DE
/

DE
EP
SUR
FA
CES

SKY
RAVE

SKY COMP. 154

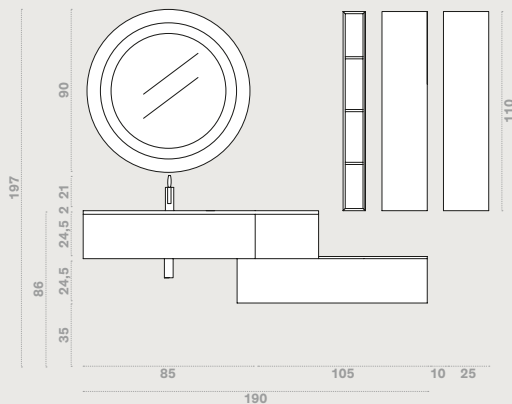

CON SPORGENZA PENSILE
L 225 x P 50,5 / 20,8 cm

SKY RAVE / COMP 154

Scocca laccata Terranova lucido e frontali con finitura Rave in tonalità Terranova / Antracite, per un bagno prestigioso in senso contemporaneo. Il piano, con lavabo integrato Walk, è realizzato in quarzo resina I-Chocolate. La forma rotonda dello specchio Planet è enfatizzata dalla lampada fluorescente integrata lungo il perimetro. I pensili sono laccati Cenere lucido con frontali in finitura Rave, nella tonalità Cenere/Bianco.

Terranova glossy lacquered shell and front panels with Rave finish in the shades Terranova / Antracite, for a prestigiously contemporary bathroom. The top, with integrated Walk washbasin, is made of I-Chocolate quartz resin. The round shape of the Planet mirror is highlighted by the fluorescent lamp integrated into its edge. The wall units are in glossy Cenere lacquer with front panels in Rave finish, in the shade Cenere/White.

Korpus lacciert in Terranova glänzend und Fronten in der Ausführung Rave, Farbe Terranova / Antracite, für ein repräsentatives Bad in zeitgemäßer Interpretation. Die Platte, mit integriertem Becken Walk, ist aus Quarz-Kunstharz I-Chocolate. Die gerundete Form des Spiegels wird durch die auf der Umfanglinie integrierte Leuchtstofflampe attraktiv betont. Die Oberschränke sind in der Farbe Cenere glänzend lacciert, Fronten in der Ausführung Rave, in der Farbe Cenere/Weiß.















SKY COMP. 155

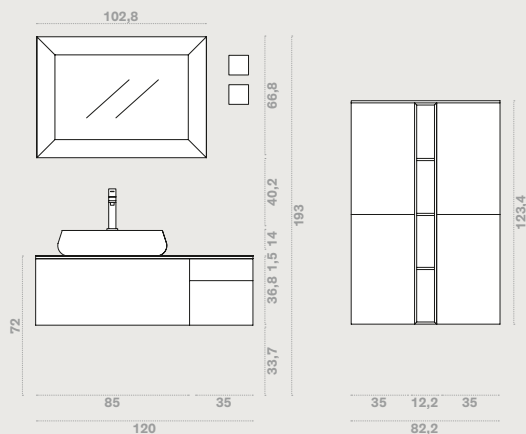

CON SPORGENZA TOP
L 121 x P 51 cm

SKY RAVE / COMP 155

Un bagno completamente vestito d'argento: dai cassettoni con finitura Rave, al piano in cristallo bicolore argento/bianco, con lavabo Geo in appoggio realizzato in mineralguss lucido. La specchiera Etnica, riprende la medesima emozione cromatica nel decoro argentato che spicca sul fondo della cornice in legno bianco. I faretti a parete Kubo completano in modo ottimale l'intera composizione.

A bathroom completely dressed in silver: from the large drawers in a Rave finish to the two-tone silver/white crystal glass top, with Geo countertop washbasin made in glossy Mineralguss composite. Etnica mirror unit reaffirms the same chromatic sensations in the silver decoration that gleams out at the bottom of the white wooden frame. Kubo wall-mounted spotlights complete the composition splendidly.

Ein vollständig silbernen bekleidetes Bad: von den Schubladenelementen in Ausführung Rave bis zur zweifarbigen Glasplatte in Silber/Weiß und Aufsatzbecken Geo aus Mineralguss glänzend. Der Spiegel Etnica greift in der silbernen Verzierung, die aus dem weißen Holz des Rahmens hervortritt, die gleichen farblichen Emotionen auf. Die an der Wand montierten Strahler Kubo vervollständigen auf ideale Weise die gesamte Einrichtung.











SKY COMP. 156



RAVE ARGENTO

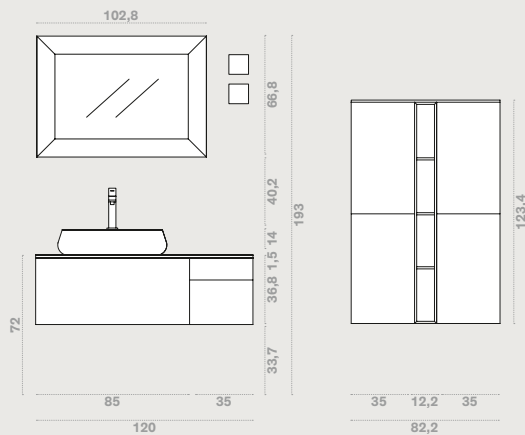

CON SPORGENZA TOP
L 121 x P 51 cm

SKY RAVE / COMP 156

La finitura Rave argento, con la sua superficie ricca di emozioni e sensazioni preziose, caratterizza completamente questa composizione formata da cassettoni pensili, piano in cristallo bicolore argento/bianco con lavabo Geo in mineralguss lucido e specchiera Etnica. Anche le colonne intervallate da vani a giorno si presentano nella medesima, affascinante finitura.

The silver Rave finish, with surface bursting with special sensations and sentiments, is the defining characteristic of this composition formed of wall-mounted drawer-units, top in two-tone silver/white crystal glass with Geo washbasin in glossy Mineralguss composite and Etnica mirror unit. The columns interposed with open compartments also feature the same enchanting finish.

Die Ausführung Rave Silber prägt mit ihrer erregenden Oberfläche und dem kostbaren Flair diese Zusammenstellung, bestehend aus hängenden Elementen mit Schubladen, zweifarbiger Glasplatte Silber/Weiß, mit Becken Geo aus Mineralguss glänzend und Spiegel Etnica. Auch die von offenen Elementen abgewechselten Säulen präsentieren sich in der gleichen, faszinierenden Ausführung.







SKY COMP. 157



RAVE ORO

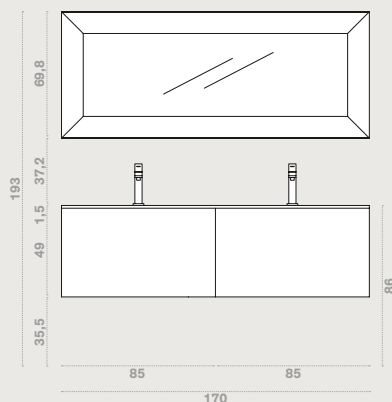

CON SPORGENZA TOP
L 171 x P 50,5 cm

SKY RAVE / COMP 157

Un ambiente bagno che non passa decisamente inosservato, in finitura Rave versione Oro lucido: il massimo dello chic. Piano in cristallo bicolore Rave Oro/Bianco con lavabo in cristallo dotato di doppio bacino rettangolare. La specchiera Guru, con cornice impreziosita da un decoro floreale dorato su fondo bianco, contribuisce al fascino irresistibile dell'insieme.

A bathroom that will not go unnoticed, in the glossy gold version of the Rave finish: the ultimate in chic. Top in two-tone crystal glass Rave gold/white with crystal washbasin featuring a double rectangular basin. Guru mirror unit, with frame embellished with a gilded floral decoration on a white background, adds to the irresistible charm of the composition.

Ein Bad, das sicherlich nicht unbemerkt bleibt, in der Ausführung Rave, Farbe Gold glänzend: Chic im höchsten Maße. Zweifarbige Glasplatte Rave Gold/Weiß mit Waschtisch aus Glas, ausgestattet mit einem rechteckigen Doppelbecken. Der Spiegel Guru trägt durch den kostbaren Rahmen mit vergoldeter Blumenverzierung zum verführerischen Zauber der Gesamtheit bei.











COMP. 152 / 05

SKY COMP. 152

SILVER LUCIDO

SKY LACCATO



ARBI

SKY COMP. 05

BIANCO LUCIDO

AMARENA LUCIDO



COMP. 153 / 74

SKY COMP. 153

BLU ELETTRICO OPACO

SKY LACCATO



ARBI

SKY COMP. 74

BIANCO LUCIDO

ARANCIO LUCIDO



COMP. 77 / 79

SKY COMP. 77

BIANCO OPACO

SKY LACCATO



ARBI

SKY COMP. 79

NEW PERGAMON OPACO



SKY REPORT



COMP. 152

PAG. 126



COMP. 05

PAG. 127



COMP. 153

PAG. 128



COMP. 74

PAG. 129



COMP. 77

PAG. 130



COMP. 79

PAG. 131



COMP. 140

PAG. 06



COMP. 141

PAG. 12



COMP. 142

PAG. 20



COMP. 143

PAG. 26



COMP. 144

PAG. 32



COMP. 145

PAG. 40



COMP. 146

PAG. 46



COMP. 147

PAG. 54



COMP. 148

PAG. 60

SKY REPORT



COMP. 149

PAG. 66



COMP. 150

PAG. 72



COMP. 151

PAG. 78



COMP. 34

PAG. 82



COMP. 33

PAG. 88



COMP. 36

PAG. 94



COMP. 154

PAG. 102



COMP. 155

PAG. 110



COMP. 156

PAG. 116



COMP. 157

PAG. 120

SKY RAVE FINITURE

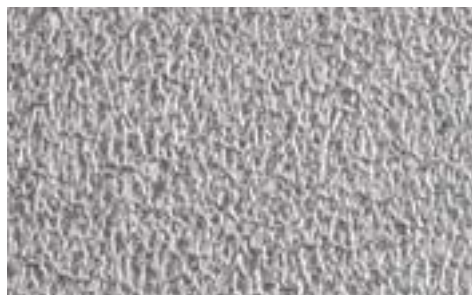

R1 Rave Argento lucido

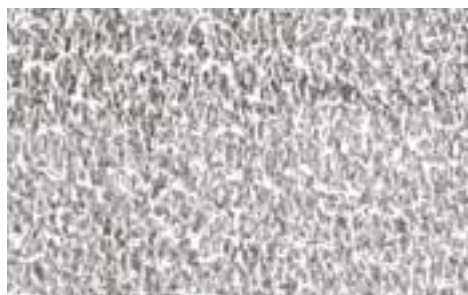

R2 Rave Argento / Bianco lucido



R3 Rave Oro lucido



R4 Rave Oro / Bianco lucido



R8 Rave Terranova / Antracite lucido



R9 Cenere / Bianco lucido

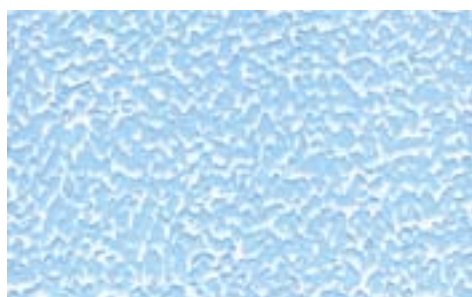

RA Maldive / Bianco lucido

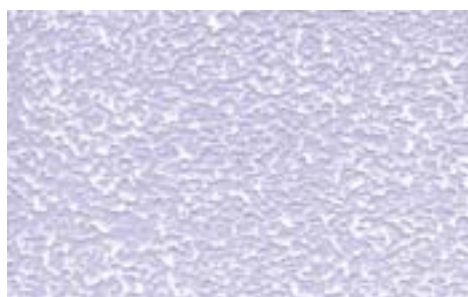

RB Lilla / Bianco lucido

LUCIDO

00 / 00 Nome Colore

OPACO

NB

Il primo colore riportato sotto al campione si riferisce alla finitura opaca, il secondo alla finitura lucida

Per la reale tonalità delle essenze e dei colori, fare riferimento al campionario

NB

The first code shown under the samples refers to the matt finish, the second to the gloss finish

For the actual shades of the wood materials and colours, refer to the sample collection

NB

Der erste Code unter dem Muster bezieht sich auf die Matt-Ausführung, der zweite auf die Glänzend-Ausführung

Für den realen Farbton der Holzarten richten Sie sich nach der Musterkollektion

SKY LACCATO OPACHI E LUCIDI



AA / LA Blue Jeans



01 / 51 Blu Elettrico



AB / LB Blu Provenza



A7 / L7 Azzurro Onda



AY / LY Maldive



02 / 52 Ceruleo



AP / LP Nuvola



AV / LV Petrolio



AD / LD Turchese



AZ / LZ Ghiaccio



19 / 69 Grigio Manhattan



AQ / LQ Cenere



AX / LX Fumo di Londra



42 / 92 Antracite



AW / LW Bosco



AE / LE Verde Amazonia



AS / LS Verde Twigg



AG / LG Corda



AH / LH Safari



AN / LN Creta



AF / LF Terranova



18 / 68 Cacao



27 / 77 Carruba



26 / 76 Nero



32 / 82 Rosso India



37 / 87 Rosso Rubino



31 / 81 Rosso Fuoco



AR / LR Tango



AO / LO Mattone



39 / 89 Arancio



30 / 80 Giallo Solare



AU / LU Polline

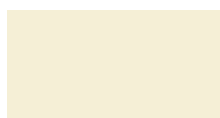

09 / 59 Ecrù

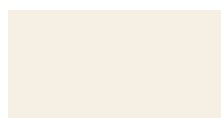

21 / 71 New Pergamon

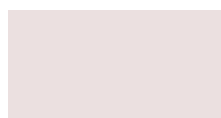

AT / LT Rosa Babol



41 / 91 Lilla



AM / LM Glicine



AL / LL Lavanda



A8 / L8 Melanzana



48 / 98 Lampone



A6 / L6 Amarena



AK / LK Ciclamino



A2 / L2 Argento



A5 / L5 Silver



A9 / L9 Metal



A1 / L1 Bronzo



A3 / L3 Oro



100 / 110 Bianco lucido

ARBI ARREDOBAGNO SRL

33070 Maron di Brugnera
Pordenone — Italy
Via le Lino Zanussi, 34/A
Tel. +39 0434 62 48 22
Fax +39 0434 62 49 91
arbi@gruppoatma.it
www.gruppoatma.it

**COLOPHON****DESIGN**

Ufficio tecnico Arbi

GRAPHIC DESIGN

Barazzuol/Malisan

PHOTOGRAPHYFotografica
Fotostudio Indoor**STYLING**Federica Baro
Adriani & Rossi**COPYWRITING**

Daniele Varelli

TRANSLATION

Studio Intra

COLOR SEPARATION

Lucegroup.it

PRINTED IN ITALY

GFP.it

—

Giugno 2012

